

SPECIFICATIONS FOR MODEL

SILENTMASTER[®]

MANUFACTURED BY
MD
CENTRAL VACUUMS

S900r2
#S2257NH 240 VOLT

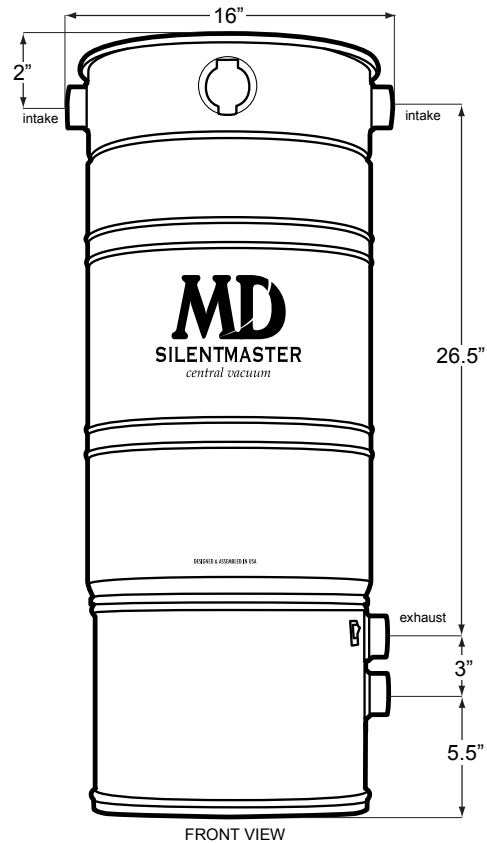
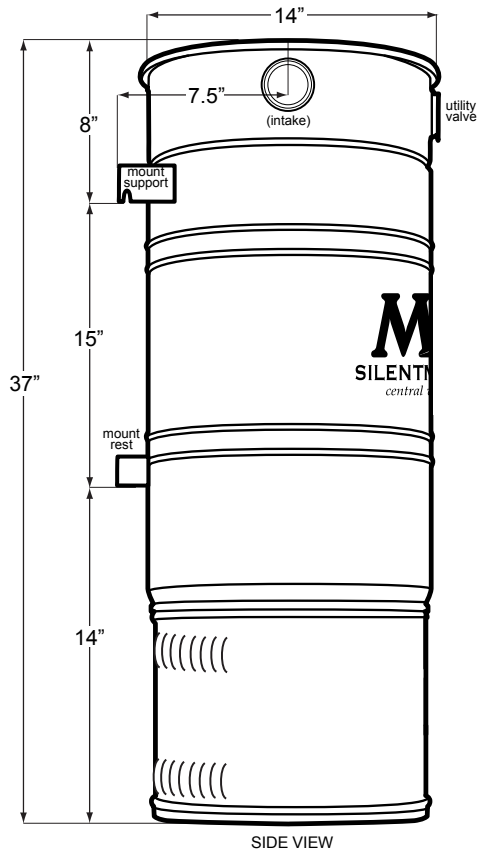

PERFORMANCE

Sealed Vacuum 136.4"
CFM 190
Air Watts 866
Volts 240
Amperage 13.7
Quietness 64 dBA
Coverage 20,000 ft²

*Recommended home size can be higher or lower when considering these factors: altitude, hours of use, complexity of pipe installation, distance of furthest inlet, noise level, type and size of filtration, and budget.

FEATURES

Motor: Two 3-stage radial bypass motors producing high CFM and Waterlift.
Filtration: Tru-Seal™ Microfiltration disposable 8-gallon bag, closed top.
Intakes: Right & left intakes. Utility valve.
Construction: Durable powder-coated all steel body.
Overload: Heat protection resettable minibreaker.

Dims/Weight: 14" Diameter, 37" Tall, 49 lbs.
Accessories: All MD accessories and kits are compatible and are sold separately.
Optional: Air Relief Valve, Mufflers.

INSTALLATION

Electrical:
240V - 50/60HZ, 15 amp circuit. Separate circuit recommended. 6' Cord with typical 240v plug. Fits NEMA 6-20R receptacle.
Mounting:
Two-stud 17" wide bracket. Easy to hang and remove. Left/right variable positioning. Mount 6" off ground. Leave 24" above unit.
Venting:
Exterior venting not necessary. 30ft maximum dual line if venting.

PROJECT	LOCATION
DEALER	DATE / PRICE



Designed & Assembled in USA

WWW.BUILTINVACUUM.COM/SILENT-MASTER

M.D. Manufacturing, Inc. 800.525.2055
34970 McMurtrey Ave. 661.283.7550
Bakersfield, CA 93308 FAX 661.283.7554