

AIRMASTER®

MANUFACTURED BY
MD
CENTRAL VACUUMS

SPECIFICATIONS FOR MODEL

A900r2Q

#A2257NH 240 VOLT

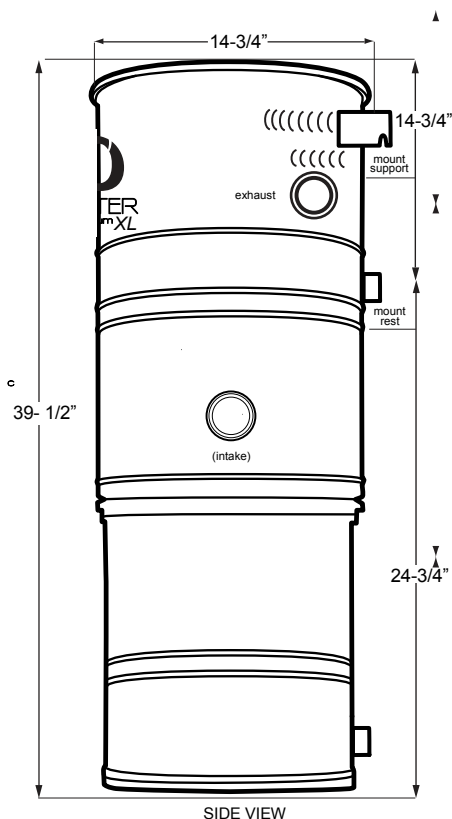

SIDE VIEW

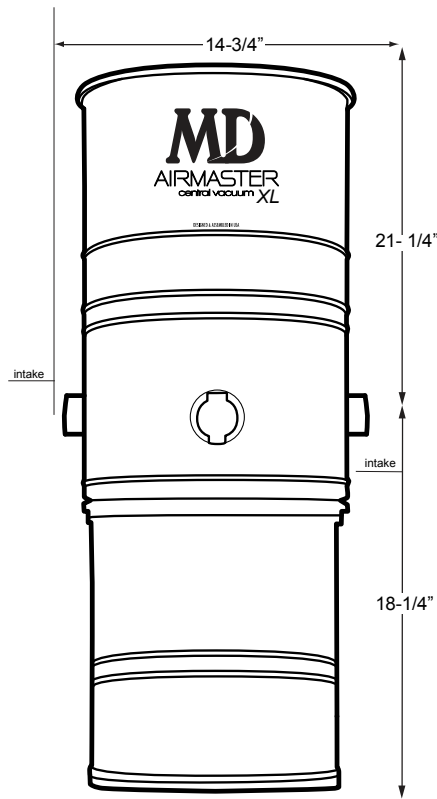

FRONT VIEW

PERFORMANCE

Sealed Vacuum 136"
CFM 190
Air Watts 866
Volts 240
Amperage 13.7
Quietness 64 dBA
Coverage 20,000 ft²

*Recommended home size can be higher or lower when considering these factors: altitude, hours of use, complexity of pipe installation, distance of furthest inlet, noise level, type and size of filtration, and budget.

FEATURES

Motor: Dual 3-stage radial bypass motors producing high CFM and Waterlift
Filtration: Tru-Seal™ Microfiltration disposable 8-gallon bag, closed top.
Intakes: Right & left intakes. Utility Valve.
Construction: Durable powder-coated all steel body.
Overload: Heat protection resettable minibreaker.
Dims/Weight: 14- 3/4" Diameter, 39- 1/2" Tall, 45 lbs.
Accessories: All MD accessories and kits are compatible and are sold separately.
Includes: Muffler and Venting Pipe.

INSTALLATION

Electrical:
240V 50/60HZ, 15 amp circuit.
Separate circuit recommended.
6' Cord with typical 120v plug.
Fits NEMA 6-20R receptacle.
Mounting:
Two-stud 17" wide bracket. Easy to hang and remove. Left/right variable positioning. Mount 6" off ground. Leave 24" above unit.
Venting:
Exterior venting not necessary.
30ft maximum line if venting.

PROJECT		LOCATION	
DEALER		DATE / PRICE	



Designed & Assembled in USA

WWW.BUILTINVACUUM.COM/AIRMASTER

M.D. Manufacturing, Inc.
34970 McMurtrey Ave.
Bakersfield, CA 93308

800.525.2055
661.283.7550
FAX 661.283.7554