

SILENTMASTER®

MANUFACTURED BY
MD
CENTRAL VACUUMS

SPECIFICATIONS FOR MODEL

S5

#S2257ND 240 VOLT

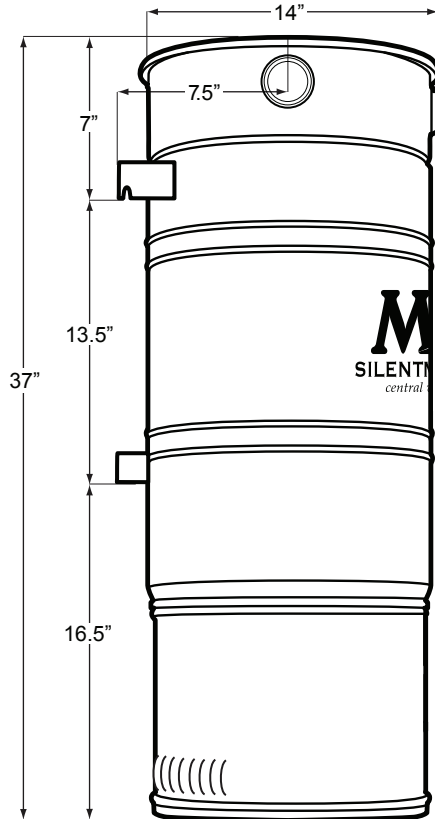

SIDE VIEW

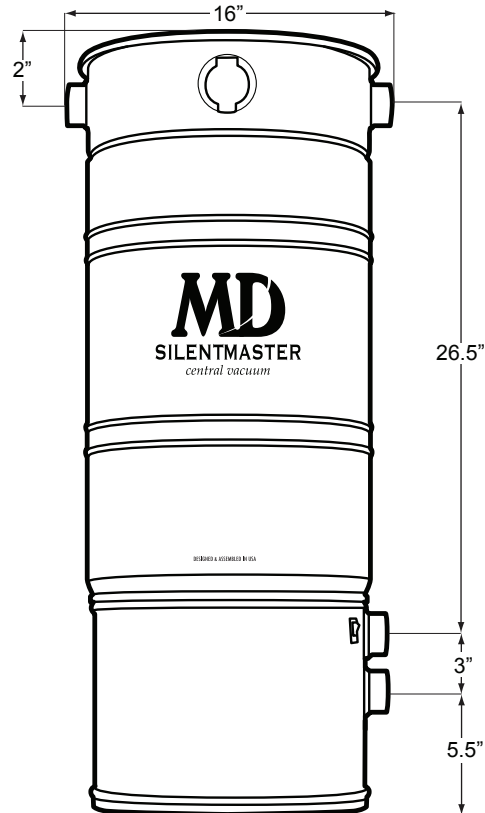

FRONT VIEW

PERFORMANCE

Sealed Vacuum 136.4"
CFM 190
Air Watts 866
Volts 240
Amperage 13.7
Quietness 62dBa
Coverage 20,000 ft²

*Excellent performance for homes up to 20,000 ft². Consider all factors when choosing a unit including air watts, altitude, usage, complexity of pipe installation, furthest inlet from unit, noise level, filtration, manufacturing origin, construction, and budget.

FEATURES

Motor: Two 3-stage motors producing high CFM and Sealed Vacuum (Waterlift).
Filtration: HyperFlow™ disposable 12-gallon bag.
Intakes: Right & left intakes. Utility valve.
Construction: Durable powder-coated all steel body.
Overload: Heat protection resettable minibreaker.
Warranty: Six Years + Lifetime on manufacturing. Find a better one and we'll match it.
Dims/Weight: 14" Diameter, 37" Tall, 49 lbs.
Accessories: All MD accessories and kits are compatible and are sold separately.
Optional: Air Relief Valve, Mufflers. Closed bag filtration.

INSTALLATION

Electrical:
240V - 50/60HZ, 20 amp circuit. Separate circuit recommended. 6' Cord with typical 240v plug. Fits NEMA 6-20R receptacle.
Mounting:
Two-stud 17" wide bracket. Easy to hang and remove. Left/right variable positioning. Mount 6" off ground. Leave 24" above unit.
Venting:
Exterior venting not necessary. 30ft maximum dual line if venting.

PROJECT		LOCATION	
DEALER		DATE / PRICE	



Made in the USA.

WWW.BUILTINVACUUM.COM/SILENT_MASTER

M.D. Manufacturing, Inc. 800.525.2055
34970 McMurtrey Ave. 661.283.7550
Bakersfield, CA 93308 FAX 661.283.7554