

Silent Master

CENTRAL VACUUM

MANUFACTURED BY
MD
CENTRAL VACUUMS

SPECIFICATIONS FOR MODEL

S44

#F116S 240 VOLT

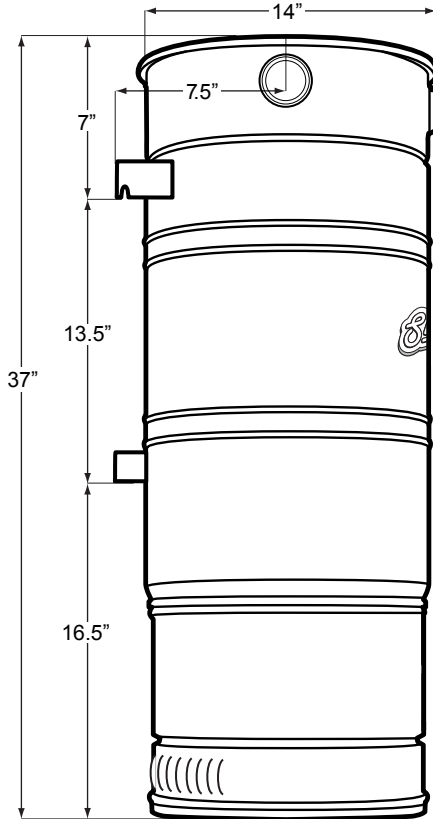

SIDE VIEW

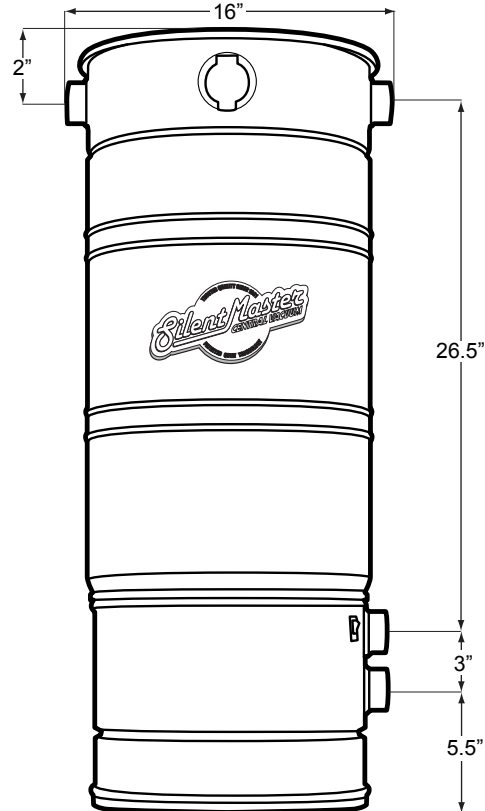

FRONT VIEW

PERFORMANCE

Sealed Vacuum 148"
CFM 130
Air Watts 653
Volts 240
Amperage 8.0
Quietness 68dBA
Coverage 8,000 ft²

*Excellent performance for homes up to 8,000 ft². Consider all factors when choosing a unit including air watts, altitude, usage, complexity of pipe installation, furthest inlet from unit, noise level, filtration, manufacturing origin, construction, and budget.

FEATURES

Motor: High performance, 2-stage motor with superior efficiency and power.
Filtration: HyperFlow™ disposable 12-gallon bag.
Intakes: Right & left intakes. Utility valve.
Construction: Durable powder-coated all steel body.
Overload: Heat protection resettable minibreaker.
Warranty: Six Years + Lifetime on manufacturing. Find a better one and we'll match it.
Dims/Weight: 14" Diameter, 37" Tall, 42 lbs.
Accessories: All MD accessories and kits are compatible and are sold separately.
Optional: Air Relief Valve, Mufflers. Closed bag filtration.

INSTALLATION

Electrical:
240V - 50/60HZ, 20 amp circuit. Separate circuit recommended. 6' Cord with standard plug fits NEMA 6-20R receptacle.
Mounting:
Two-stud 17" wide bracket. Easy to hang and remove. Left/right variable positioning. Mount 6" off ground. Leave 24" above unit.
Venting:
Exterior venting not necessary. 30ft maximum dual line if venting.

PROJECT		LOCATION	
DEALER		DATE / PRICE	

Made in the USA.

WWW.BUILTINVACUUM.COM/SILENT_MASTER

M.D. Manufacturing, Inc. 800.525.2055
34970 McMurtrey Ave. 661.283.7550
Bakersfield, CA 93308 FAX 661.283.7554